

Implementation and performance Analysis of Grid Connected PV-Wind-BES system under Critical Load Conditions

O. Thireesh¹, P. Ramesh², G. Charitha³, U. Madhuri⁴, SK. Anwar⁵, V. Prem Kumar⁵

^{1&2}Assistant Professor, ^{3, 4,5&6} UG Student

^{1,2,3,4,5&6}Electrical and Electronics Engineering, Sree Venkateswara College of Engineering-Nellore, Andhra

Article Info

Volume 9, Issue 3

Page Number : 455-466

Publication Issue

May-June-2022

Article History

Accepted : 01 June 2022

Published : 07 June 2022 Pradesh, India

ABSTRACT

This research work presents, an

implementation of micro-grid system by interconnecting the renewable energy sources of photovoltaic (PV) and wind power generation (WPG) along with a battery energy storage system (BESS). The renewable energy sources plays an important role to produce electrical energy without using any fossil fuels. Because of fossil fuels based power generation produce environmental pollution and also increases load demand on system which leads shortage of fossil fuels due to this power outages may be occurs. Because of this reason, this paper investigate the performance of renewable energy sources like PV-WPG system. The PV and WPG system mainly depends upon environmental changes and connected load. So, these two systems (PV-WPG) form the micro grid and controlled by MPPT topology. The MPPT strategy helps to produce maximum power from this two system (PV-WPG). This microgrid performance tested under different environmental changes and critical load conditions in this paper. This proposed work implemented and tested in MATLAB/SIMULINK software.

Keywords : Photovoltaic System, Wind Power Generation, Microgrid, Battery Energy Storage System.

I. INTRODUCTION

India has suffered a significant energy issue in the last decade as a result of population expansion, and it is largely reliant on fossil fuel imports. Renewable energy is now a viable option for meeting electricity demand. Because of its benefits, its integration has gotten a lot of attention. Photovoltaic (PV) and Wind Turbine (WT) systems, for example, have become particularly appealing because to their

widespread availability, technological advancement, and economic benefits. The hybrid combination of the two avoids mutual intermittences, increasing system reliability. More and more, Hybrid Renewable Energy Systems are becoming a necessary technique for distributing electrical energy to remote and inaccessible places. Hybrid generation systems merge solar energy with electricity generation of WT [1].

The penetration of solar PV and onshore wind generation into Nigeria's present energy grid is

investigated. The study's goal is to identify the maximum capacity of solar and onshore wind generating plants that can be integrated into Nigeria's current electrical infrastructure [2].

Solar hybrid power systems combine solar energy from a photovoltaic system with another energy source to generate electricity. During the winter, the wind turbine would produce more energy, while the solar panels would provide their maximum output during the summer. Wind, solar, geothermal, and trigeneration stand-alone systems can provide better economic and environmental returns than hybrid energy systems [3]. It is critical to provide a hybrid solar-wind energy system to power ICT infrastructures, banking, and hospitals in rural and underserved communities that are not connected to the National Grid Power Supply System in order to ensure a steady supply of electricity. When considering cost and overall efficiency, it is recommended that all stakeholders concerned with the development of rural communities utilize solar and wind power [4]. The term microgrid refers to a power system that uses distributed energy sources and is classified based on its function rather than its size. The current electricity system must deal with technological and societal advances, as well as economic issues. For power engineers, the system, difficulties, and protection in the power system are a difficult challenge, and the requirement for a secure power system is critical. Electricity quality must be adequate, and energy must be available at all times. Electricity supply costs must be reasonable, and energy efficiency must be present in all parts of energy usage. These issues are crucial in the development of microgrids, an energy network that aims to address the shortcomings of today's systems in order to improve the generation and usage of electricity. The microgrid can operate in an island mode, which is particularly beneficial in the event

of a power outage or in transporting electricity to remote locations, but the regulation of frequency, voltage, reactive and active power is a challenge in this mode of operation [5].

In a grid-connected MG system, the utility manages the system dynamics, but in an islanded MG system, the micro sources control the dynamics. MG operates as a single controlled entity, or aggregated load, within the power system, supplying uninterruptible power to meet local electrical/heat requirements, increasing dependability, reducing losses, and providing good voltage support. The micro sources are managed in utility connected mode of operation to supply the specified power into the system, and the microgrid should be structured in such a way that a smooth transition from grid linked to isolated mode or vice versa occurs based on grid conditions. When working in stand-alone mode, sources are managed so that all local loads are supplied by micro-sources, maintaining the required voltage and frequency [6].

A Microgrid Platform (MP) is a sophisticated EMS for microgrid operations. We create the MP by considering I all of a microgrid EMS's functional requirements (such as optimization, forecasting, human-machine interface, and data analysis) as well as (ii) engineering problems (i.e., interoperability, extensibility, and flexibility) [7]. In comparison to single-use of such systems, combining these renewable energy sources with backup units to form a hybrid system can provide a more cost-effective, environmentally friendly, and stable supply of electricity in all load demand scenarios. One of the most essential considerations in this sort of hybrid system is to size the hybrid system components to fulfil all load needs with the lowest possible investment and running expenses. Since the increasing popularity of renewable

energy sources, several studies have been conducted on the optimization and sizing of hybrid renewable energy systems [8].

Microgrids can help them satisfy their special needs, such as boosting local reliability, lowering feeder loss, and maintaining local voltage stability, among other things. Microgrid and large grid exchange energy via PCC (Point of Common Coupling), and the two sections are redundant, boosting power supply dependability [9].

The microgrid concept is appealing from a grid perspective because it acknowledges the fact that the nation's distribution system is huge, outdated, and will only alter slowly. The microgrid idea allows for significant DG penetration without requiring the distribution infrastructure to be redesigned or reengineered [10].

This paper is organized as follows: In Section 2, the system description about solar, wind battery, MPPT, active-reactive power control and microgrid. Section 3. Proposed system about microgrid along with control topology, Section 4, simulation work and results discussion. Section 5 discusses about conclusion.

II. System Description

The proposed system is a hybrid/combination of two separate systems, such as solar and wind. The following is a block-by-block description:

A. Solar Panel:

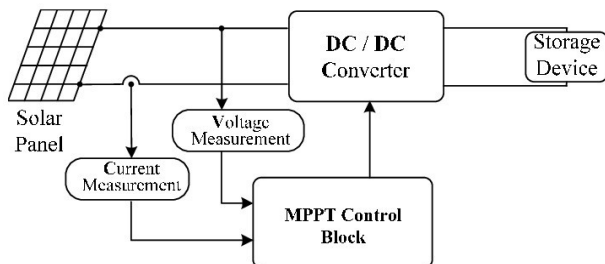

Fig.1. Block diagram of solar power generation

Solar panels / photovoltaic panels are used to convert solar energy into electrical energy. The working principle of a solar panel is light effectedsemiconductors. Since the entire ecosystem on planet Earth is dependent on solar energy, which is a vast and never-ending source of energy. It is recommended for the project because of its ease of interpretation, quantity of sources, and popularity. Solar panels are photovoltaic, meaning they create electricity from the sun's rays. The amount of electrical DC energy produced depends on the position and intensity of the sun's light.

B. Solar maximum power point tracking (MPPT) topology

The sun energy in the earth is not constant because the sun rotates 0 to 180 degrees in nature and shadow effects reduce the sun energy. Because of this reason the power from the solar panels are low. To overcome this drawback utilized different types of MPPT topologies in solar power generation. The name itself indicates extracts the maximum power from the solar panels. There are different types of MPPT topologies utilized for solar power generation. In this project implemented P&O MPPT topology

C. Perturb and observe (P&O) method

In this procedure, the controller adjusts the voltage from the array by a small amount and monitors power; if power grows, the controller tries more adjustments in that direction until power no longer increases. This is known as the P&O method, and it is the most prevalent, despite the fact that it can

cause power output fluctuations. Because it is based on the increase of the power against voltage curve below the maximum power point and the fall above that point, it is referred to as a hill climbing method. Because of its simplicity, perturb and observe is the most often utilised MPPT approach. If an appropriate predictive and adaptive hill climbing approach is used, the P&O method may result in top-level efficiency. The flow chart for the P&O method is shown in the block figure below.

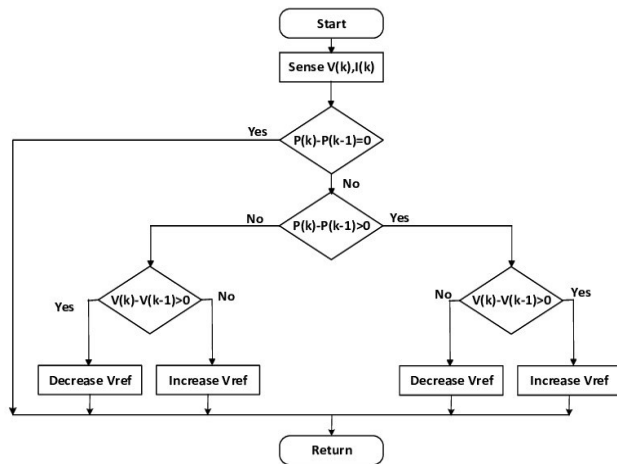

Fig.2. P&O method flow chart

D. Wind Turbine

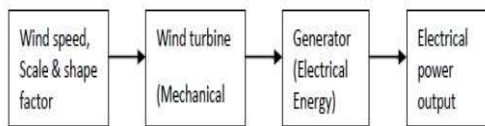

Fig.3. Block diagram of wind power generation In the eco system of the earth, wind is present 24 hours a day. Wind turbines have huge blades that are connected to the rotor of a generator, allowing them to produce electrical energy while moving with the wind. Wind energy is also a renewable, never-ending source of energy that is readily available in the atmosphere. Wind turbine power plants are far more popular, owing to their higher efficiency when compared to the amount of space required for installation.

A wind turbine is a mechanical device or machine that uses renewable wind energy to generate electricity. The amount of electrical energy produced will be determined by the wind speed. Wind power generation is controlled by active and reactive power control topology in this paper.

E. Active and Reactive power control topology

Power electronics converters are incorporated into wind energy conversion systems to improve control and interconnection to the electricity grid system.

The emphasis is now primarily on power schemes that provide total control of active and reactive power at all operating points by utilising a partialscale power electronics converter or a full-scale power electronics converter. The wind turbine system's generated active power is controlled by the generator side converter, whereas the reactive power is controlled by the electricity grid side converter. In this case, a DC chopper is typically used to prevent DC-link overvoltage in situations of electricity grid faults, when additional turbine power must be dissipated due to a sudden drop in electricity grid voltage.

F. Batteries

The electrical energy generated by the system must either be used entirely or stored. It is impossible to use all of the energy produced by the system all of the time. As a result, rather than wasting it, it should be stored. The most relevant, low-cost, and most effective storage of electrical energy in the form of a chemical reaction is electrical batteries. As a result, batteries are the preferable option.

The energy produced by the proposed project must be stored. Battery energy storage system required

which is connected to combination of solar-wind dc link.

G. Inverter

An inverter is an electrical device that converts direct current (DC) to alternating current (AC). The batteries' stored electrical energy is DC in nature. It also can't be used for a variety of loads. As a result, delivering AC power to the load inverter system is necessary. An inverter might be analogue or digital. The digital inverter is microcontroller-based, which increases the system's build-up cost. It also incorporates MOSFET technology, which increases efficiency. However, the proposed project designs and builds an analogue inverter in nature, taking into account the economical aspect and resolution. The below figure shows the proposed solar-wind and battery block diagram.

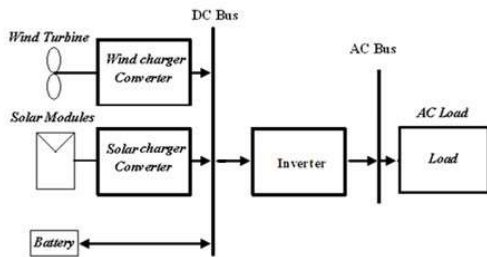

Fig.4.block diagram of battery connected solar and wind system

III. Proposed Topology

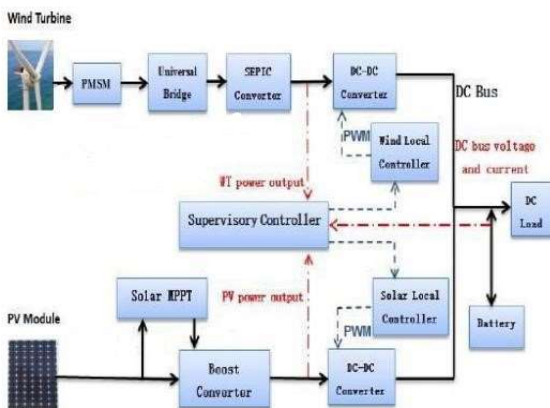

Fig.5. the Proposed Hybrid System for Solar and Wind Power System

The diagram depicts the proposed hybrid solarwind power system in detail. This hybrid system generates electricity using both solar and wind energy, and uses converters to adjust the amount of energy sent to the battery. This technology aids in the maintenance of a consistent and reliable power supply with the desired rating for charging the battery and powering the load. For solar power sources, the perturb and observe method is used to track maximum power. To supply the load and the battery, two branches are connected in parallel. MPPT and voltage source converters control the power sources. The MPPT is achieved in solar by adjusting the controller and regulating the converters.

In this the PV array is connected to boost converter, DC/DC converter, through solar MPPT to load and also to the battery. The power obtained by the PV system is applied to the boost converter to step up the voltage with a maximum power point tracker. The maximum power tracking from PV array is done with the help of perturb and observe method for solar power source. The solar irradiance is efficient under standard conditions of temperature 25°C and irradiance of 600W//m2. The control system charges and discharges the battery in accordance with setting the voltage at specified range. When one of the sources is voltage controlled other will be current source.

In this the wind generation system consists a generator and a turbine are used to transform mechanical energy into electrical energy in a wind energy system. A variable-speed wind turbine and a permanent magnet synchronous generator (PMSM) are included in this system. The maximum speed is

attained by increasing the rotor speed. To set the dc and maintain the power sources and storage system for a supervisory control system. The control system charges and discharges the battery according to the voltage range defined by the user.

The output of wind turbine is connected to PMSM to track the torque command given by the wind turbine at any given set of inputs. There is dc link decoupling between wind turbine and electricity grid.so as to improve and its control and interconnection to the electricity grid system the controlling topology using active and reactive power topology for wind generation system with the energy storage management to provide the power for local grids.

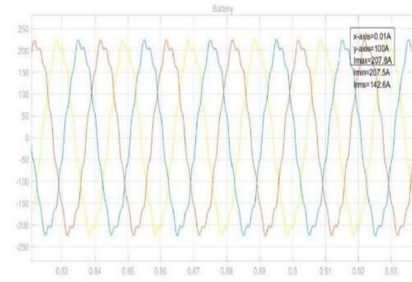

Fig. 7. Grid Current curves connected to Battery system while charging

b) Battery SoC

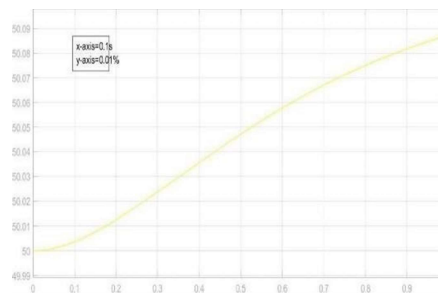

Fig.8. SoC of the battery while charging
B. During Dis-charging Mode

a) Grid Voltage

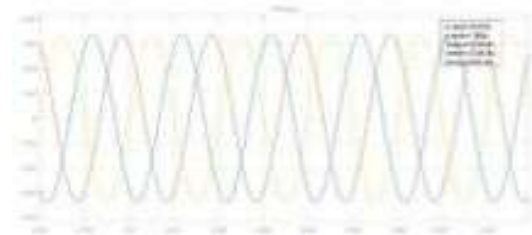

Fig. 9. Grid Voltage curves connected to Battery system while discharging

b) Grid Current

IV. Simulation results and discussion

A. During charging mode

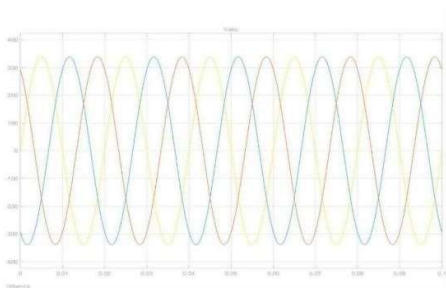

Fig.6. Grid Voltage curves connected to Battery system while charging

a) Grid Current

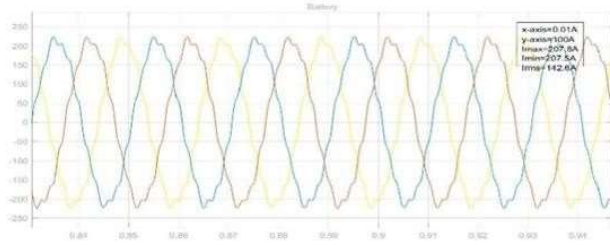

Fig.10. Grid Current curves connected to Battery system while discharging

c) Battery SoC

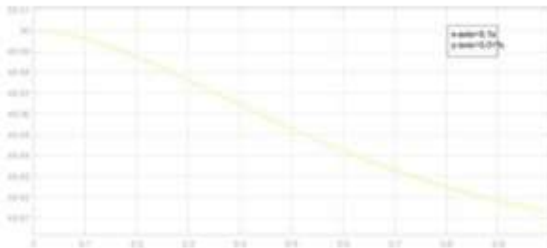

Fig.11. SoC of the battery while discharging

C. CONTROL UNIT

The basic ideology of this module is to control the power-flow between grid, battery and load. With some parameter like SOC of battery, voltage and current from wind, solar and load systems. Based on the power available and consumed a logic have been developed to control battery charging state.

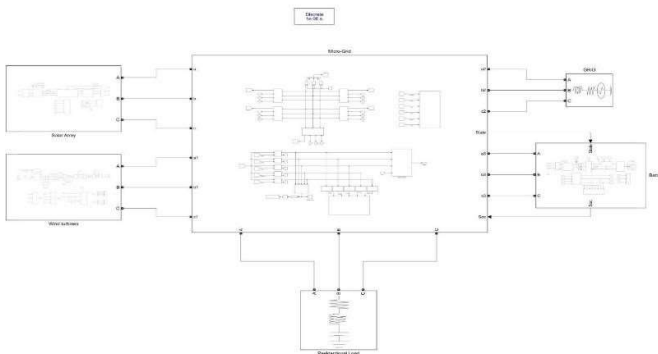

Fig 12. Micro grid

The above figure shows all the circuital connections between solar arrays, wind turbines, load, grid and battery along with control module. A constant residential load of 50KVA is considered at 415V and 250A. Power is flown through all the connections shown above. Except for the SOC and state connections, where they represent signals.

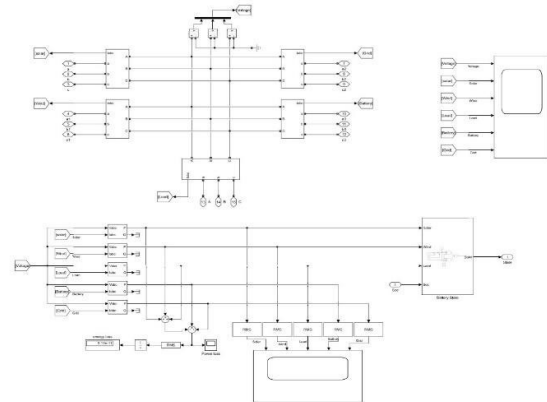

Fig. 13. Figure of Control Unit

Voltage and current from the respective stations were taken and power generated or consumed is being calculated. Active power generated (power has positive value) from wind turbines and solar array is added to active power drawn (power has negative value) by the load, battery and grid. Which gives us the power loss. By integrating this power loss with respect to time, energy loss is calculated.

D. BATTERY STATE CONTROL

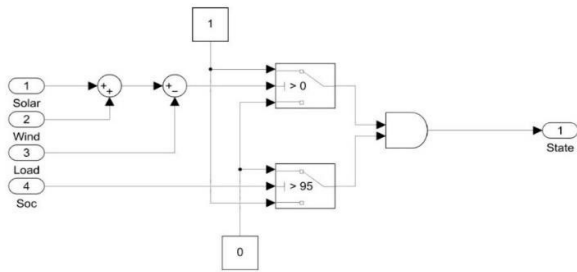

Fig. 14. Figure of Battery Logic

Firstly total power generated is calculated by adding the solar power and wind power. And then the power drawn by the load from the total generated power. And remaining power (R) will be either -/+ and $R < 0$ indicates logic 0, $R > 0$ indicates logic 1. Similarly SOC $< 95\%$ indicates

logic 0. From the 8.3 getting both logics and after Fig.17.rms power consumed by load the AND-gate operation. Logic 1 indicates battery is in charging mode & logic 0 indicates battery is in discharging mode.

Then following 4 cases are possible -

- i) When $R < 0$ & SoC $> 95\%$, Battery is in Discharging mode.
- ii) When $R < 0$ & SoC $< 95\%$, Battery is in Discharging mode. Fig.18.RMS power output from battery

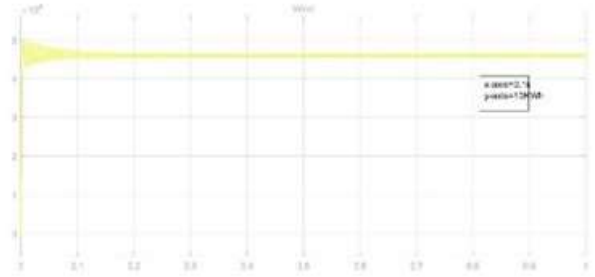
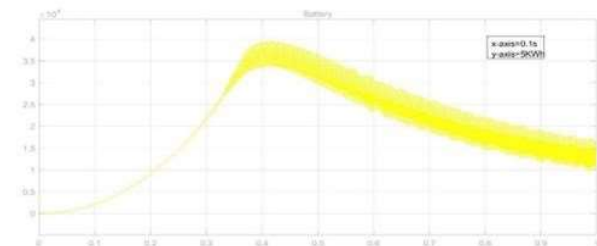
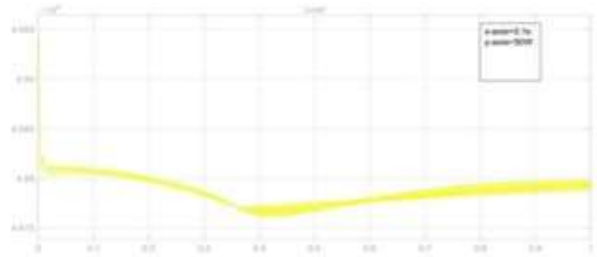

Fig.16. RMS power output from wind turbine



iii) When $R > 0$ & SoC $> 95\%$, Battery is in Dis - charging mode. When $R > 0$ & SoC $< 95\%$, Battery is in Charging mode.

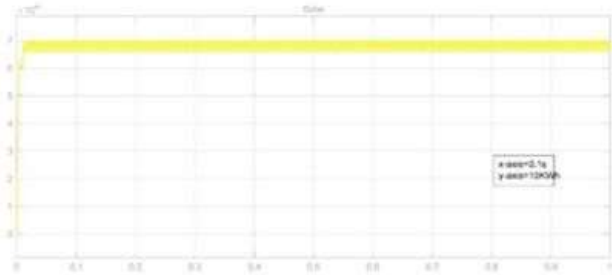

Fig.15.RMS power output waveform from solar PV array

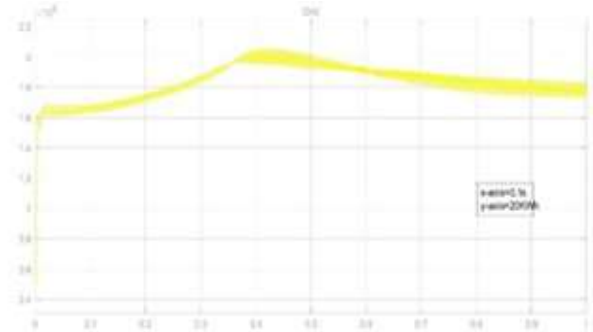

Fig.19.RMS voltage at grid

Table-1: corresponding for above RMS Power

System parameters	P(rms) in KWh	P(avg) in KWh	Peak to peak Power in KWh	Ripple factor	Form factor
Solar	68.2	68.14	69.98	0.0419	1.00088
Wind	46.12	46.09	50.03	0.036	1.0007
Load	49.791	49.79	0.18	0.00634	1.00002
Battery	21.82	20.4834	39.6	0.3671	1.06525
Grid	183.4	183	155.3	0.0662	1.0022

Graphs

E. Output rms power from solar array, wind turbine, load, battery & grid were shown in this

$$\text{Form Factor} = P(\text{rms})/P(\text{avg})$$

$$\text{Ripple Factor} = (\text{FF}^2 - 1)^{0.5}$$

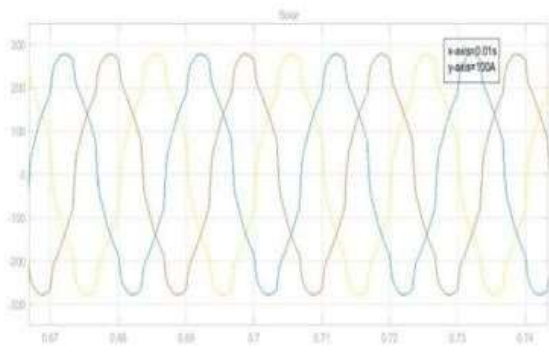

Fig.20. Voltage graphs of Solar

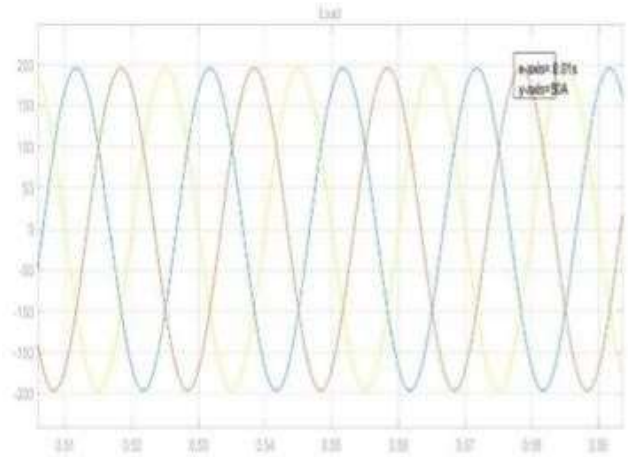

Fig.22. Voltage graphs of Load

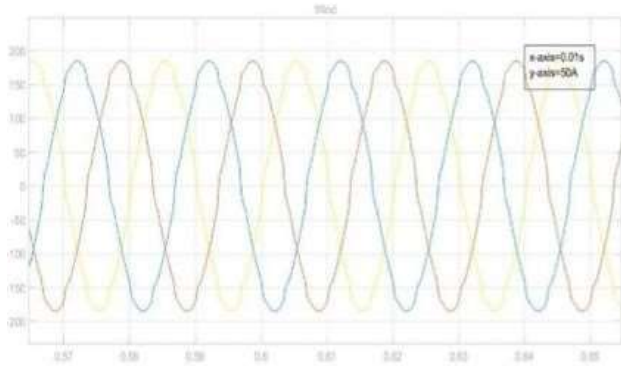

Fig.21. Voltage graphs of Wind

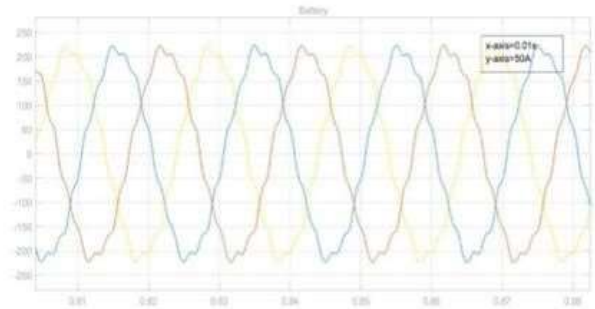

Fig. 23. Voltage graphs of Battery

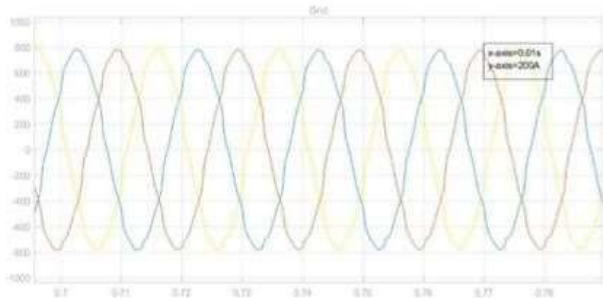

Fig.24. Voltage graphs of Grid

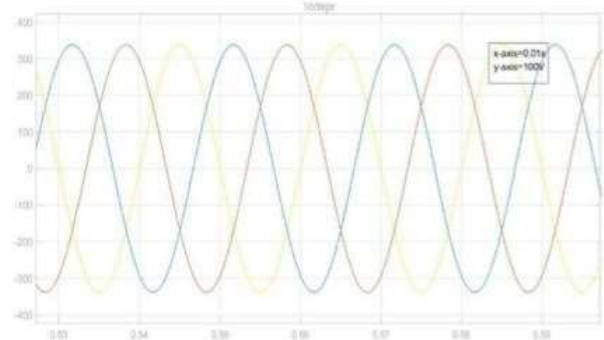

Fig.25. Voltage graph of the PCC

Table-2: corresponding for above 3phase- I Graphs

System parameters	I _{ph rms} in (A)	I _{avg} in (A)	I(p-p) in (A)
Solar	189.2	-11.74	555.8
Wind	129.7	2.45	369.2
Load	137.2	1.01	392.6
Battery	153.6	0.845	447.6
Grid	550.8	-19.4	1562

Voltage is kept constant for all the systems,

- i) $V_{ph.max} = 338.1$ V & Time for $V_{ph.max} = 0.805$ s,
- ii) $V_{ph.min} = -338.1$ V & Time for $V_{ph.min} = 0.815$ s,
- iii) $V_{rms} = 2.368e + 02$ V

Main Grid (Central grid) acts as sink i.e., whenever excessive power is generated and battery SoC > 95%, remaining power is taken by main grid.

All ripple factors calculated fall into acceptable range i.e., 20 - 40% and energy lost obtained from simulation is of 0.000919 uJ which is very negligible.

V. CONCLUSION

It is concluded that if there is a lot of sunlight and wind energy available, then these two sources are very useful for generating electrical energy. The micro-grid system by interconnecting the renewable energy sources of photovoltaic (PV) and wind power generation (WPG) along with a battery energy storage system (BESS) implemented in MATLAB/SIMULINK Software. In solar power generation utilized P&O MPPT topology to extract maximum power from the solar panel and similarly utilized active and reactive power control topology for wind power generation to get the stable output. The BESS implemented to maintain uninterrupted power supply for microgrid and load. The PV and WPG system tested under different

environmental changes and critical load conditions. The Proposed system gives best alternative solution for fossil fuel power generation systems.

VI. REFERENCES

- [1]. Muhammad Zeeshan Malik., Ubedullah., Vishesh Kumar., Kanza Zehra., Muhammad Ismail., Mir Abid., Irfan Ali., Abid Hussain., Mazhar H.Baloch., Solar-Wind Hybrid Energy Generation System. 978-IEEE 23rd international multitopic conference. 1-7281-9893-4/20/\$31.00 ©2020 IEEE. DOI:10.1109/INMICC50486.2020.9318083
- [2]. Olusola Bamisile., Patrick Ayambire., Serkan Abbasoglu., Qi Huang, IEEE Senior member., Paul O.K. Anane., Weihao Hu, IEEE Senior member., Analysis of Solar PV and Wind Power Penetration into Nigeria Electricity System. ,2020 at 15:47:35 UTC from IEEE Xplore.
- [3]. Pritesh P. Shirsath¹ , Anant Pise² , Ajit Shinde , Solar-Wind Hybrid Energy Generation System. International Journal of Engineering Research and General Science Volume 4, Issue 2, March-April, 2016
- [4]. Mr. Sthita Prajna Mishra, Dr.S.M.Ali, Ms. Prajnasmitha Mohapatra, Ms. Arjyadhara Pradhan., A Hybrid System (Solar and Wind) Energy System for Remote Areas. International Journal of Engineering Research and Development eISSN : 2278-067X, pISSN : 2278800X, www.ijerd.com Volume 4, Issue 8 (November 2012), PP. 64-68.
- [5]. Lejla Terzić · Aiša Ramović · Ajla Merzić · Adnan Bosović · Mustafa Musić., Analysis of the implementation of microgrid. SN Applied Sciences (2019) 1:33 | <https://doi.org/10.1007/s42452-018-0036-5>

- [6]. V Lavanya, N Senthil Kumar ., A Review: Control Strategies for Power Quality Improvement in Microgrid. INTERNATIONAL JOURNAL of RENEWABLE ENERGY RESEARCH V. Lavanya and N. S. Kumar , Vol.8, No.1, March, 2018.
- [7]. Eun-Kyu Lee , Wenbo Shi , Rajit Gadh 2 and Woosong Kim , Design and Implementation of a Microgrid Energy Management System. Sustainability 2016, 8, 1143; doi:10.3390/su8111143.
- [8]. Xuesong Zhou, Tie Guo and Youjie Ma., An Overview on Microgrid Technology. Proceedings of 2015 IEEE international conference on mechatronics and automation.
- [9]. R. H. Lasseter1., Microgrids and Distributed Generation. JOURNAL OF ENERGY ENGINEERING © ASCE / SEPTEMBER 2007.
- [10]. O. Erdinc , M. Uzunoglu., Optimum design of hybrid renewable energy systems. O. Erdinc, M. Uzunoglu / Renewable and Sustainable Energy Reviews 16 (2012) 1412–1425.

Authors profile:



Mr. O. THIREESH, received graduate degree in electrical and electronics engineering from JNTUH, HYDERABAD and post graduation degree specialisation of electrical power systems from JNTUK, KAKINADA and presently working as assistant professor in EEE Department At Sree Venkateswara College of Engineering, North Rajupalem, S.P.S.R Nellore, A.P.

E-mail: triteesh.electrical@gmail.com



MR.P.RAMESH received graduate degree in electrical and electronics engineering from JNTUA, Anantapuramu and post graduation degree specialisation of electrical power systems from JNTUA, Anantapuramu and presently working as assistant professor in EEE Department At Sree Venkateswara College of Engineering, North Rajupalem, S.P.S.R Nellore, A.P.

E-mail I'd:- ramesh.prams@gmail.com



G.CHARITHA is Pursuing B.TECH in Electrical And Electronics Engineering from Sree Venkateswara College of Engineering, North Rajupalem, S.P.S.R Nellore, A.P.

E-mail :- gallacharitha@gmail.com



U.MADHURI is Pursuing B.TECH in Electrical And Electronics Engineering from Sree Venkateswara College of Engineering, North Rajupalem, S.P.S.R Nellore, A.P.

E-mail

[:uppalamadhuri5@gmail.com](mailto:uppalamadhuri5@gmail.com)



SK.ANWAR is Pursuing B.TECH in Electrical And Electronics Engineering from Sree Venkateswara College of Engineering, North Rajupalem, S.P.S.R Nellore, A.P.

E-mail

anwarshaik2444@gmail.com

:-



V.PREM KUMAR is Pursuing
B.TECH in Electrical And
Electronics Engineering from
Sree Venkateswara College of
Engineering, North Rajupalem,
S.P.S.R Nellore, A.P.

E-mail :-

premkumarv121@gmail.com

Cite this article as :

O. Thireesh, P. Ramesh, G. Charitha, U. Madhuri, SK.
Anwar, V. Prem Kumar, "Implementation and
performance Analysis of Grid Connected PV-
WindBES system under Critical Load Conditions",
International Journal of Scientific Research in Science
and Technology (IJSRST), Online ISSN : 2395-602X,
Print ISSN : 2395-6011, Volume 9 Issue 3, pp. 455-466,
May-June 2022.

Journal URL : <https://ijsrst.com/IJSRST2293103>