



## IMPLEMENTATION OF MODIFIED MPPT TECHNIQUE FOR MITIGATION OF INTERHARMONICS IN PV SYSTEMS

<sup>1</sup>T. Srikanth,<sup>2</sup> P. Ramesh, <sup>3</sup>G. Siva Kumar, <sup>4</sup>P. Beaula,<sup>5</sup>K. Venkata Vivek

<sup>1</sup>Associate Professor, <sup>2</sup>Assistant Professor, <sup>3,4,5</sup>UG Scholar, Dept. Of E.E.E

<sup>1,2,3,4,5</sup>Sree Venkateswara College of Engineering, North Rajupalem, Nellore, A.P

### ABSTRACT:

In this paper, mitigation of interharmonics in grid connected PV system is proposed. These interharmonics are emitted by PV inverters primarily as a result of the MPPT technique. This paper proposes a new mitigating solution for interharmonics in PV systems to address this issue. The proposed method modifies MPPT's sampling rate in order to select between fast and slow sampling rates. When the MPPT sampling rate is set to random, the interharmonics in the output PV current are reduced, and the MPPT efficiency is the same as when the sampling rate is set to fast. The proposed interharmonic mitigation strategy has been tested experimentally on a single-phase grid-connected PV system.

### 1.INTRODUCTION

With the increasing level of Photovoltaic (PV) systems, testing issues with framework coordination have emerged in the last decade. Interharmonics, which are defined as recurrence parts that are non-number occasions of the principal recurrence, are one of the emerging power quality issues for network-connected PV systems [1]. Ongoing research has revealed that PV inverters are the most likely source of interharmonic emanation for PV systems, as observed in both the research centre testing

climate and field estimations [2]-[6]. Despite the fact that the interharmonics standard is still a work in progress, interharmonics can cause matrix voltage changes, glinting, and the unintentional detachment of PV systems. While duplicating the abundancy of the output current  $|i_g|$  with the stage point  $\sin(\theta_g)$ , the output current  $i_g$  will contain a specific measure of interharmonic frequencies because of the adequacy regulation after the control outline in Fig. 1. Characteristic in PV systems has been proposed in [8], where the interharmonic model results agree well with the field perception in [6]. [8] demonstrates that the interharmonic trademark is heavily reliant on MPPT algorithm parameters such as the irritation step-size  $v_{step}$  and sampling rate  $f_{MPPT}$ . As demonstrated in [8,] interharmonic emission can be successfully reduced by lowering the sampling rate of the MPPT algorithm. However, this will undoubtedly slow down the MPPT algorithm's tracking execution [9], which may reduce MPPT proficiency and thus PV energy yield, particularly during changing natural conditions (e.g., solar irradiance and surrounding temperature). As a result, there is a compromise between interharmonic emission and MPPT proficiency while choosing the sampling rate

of the MPPT algorithm. the above inspiration, another relieving answer for interharmonics in PV systems is proposed in this paper. The proposed technique randomly switches the activity between a fast and slow sampling rate of the MPPT algorithm. Thusly, the interharmonics in the output current can be successfully diminished because of the conveyance of the frequency range. Then again, the MPPT execution of the proposed technique can be kept up like the situation while utilizing a fast MPPT sampling rate.

**II.INTERHARMONIC EFFECTS**

Interharmonics, like harmonics, add extra signals to the power system. These extra signals can have a variety of effects, particularly if they are amplified by reverberation. The greater the range of frequencies present, the greater the risk of reverberation. Many of the effects of interharmonics are similar to those of harmonics, but some are unique to interharmonics due to their non-intermittent nature.

Inter harmonic effects, like those caused by an extra sign superimposed on the crucial, are classified into three types: overloads, oscillations, and distortion. Overload effects include extra energy losses that can contribute to warming, overloading filters or other system components, and current transformer immersion. These extra signals, depending on their frequency, can cause oscillations in mechanical systems, acoustic disturbances, or interfere with telecommunication signals. The activity of gear synchronised with system zero-intersections or reliant on a predictable peak voltage, such as glaring lights, timing gadgets, and some electronic hardware, can be hampered by distortion of the major frequency waveform. Two of the most well-known and significant effects of interharmonics that are not related to symphonic distortion are are light flicker and power line communication impedance, the two of which require non-occasional signs to happen.

**III.PROPOSED SYSTEM**

The proposed the single-stage single-phase PV inverter shown in Fig. 1, where the system parameters are given in Table I. In this configuration, the PV inverter is employed to control the power extraction from the PV arrays and convert it to the ac power delivered to the grid [10]. In order to maximize the PV energy yield, the operating voltage of the PV arrays (i.e., corresponding to the dc-link voltage  $v_{dc}$ ) is determined by the MPPT algorithm during the operation. The dc-connect voltage  $v_{dc}$  is managed through the control of the output current  $i_g$  by a current regulator, where the stage point of the output current  $\sin(\theta_g)$  is acquired utilizing a Phase-Locked Loop (PLL).

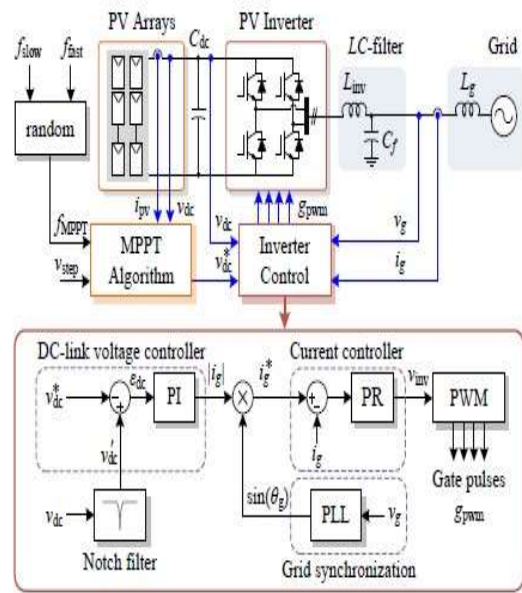

Fig. 1. System diagram and control structure of single-stage single-phase PV inverter (PI - Proportional Integral, PR - Proportional Resonant, PWM - Pulse Width Modulation, PLL - Phase-Locked Loop).

TABLE I  
PARAMETERS OF THE SINGLE-PHASE GRID-CONNECTED PV SYSTEM.

PV rated power	3 kW
DC-link capacitor	$C_{dc} = 1100 \mu\text{F}$
LC-filter	$L_{inv} = 4.8 \text{ mH}, C_f = 4.3 \mu\text{F}$
Grid-side inductance	$L_g = 2 \text{ mH}$
Switching frequency	$f_{sw} = 8 \text{ kHz}$
Controller sampling frequency	$f_s = 20 \text{ kHz}$
Grid nominal voltage (RMS)	$V_g = 230 \text{ V}$
Grid nominal frequency	$f_g = 50 \text{ Hz}$

Maximum Power Point Tracking the MPPT algorithm is basic for the PV system to keep up the working point of the PV clusters near the MPP and in this way augment the energy yield during the activity. In this paper, the Perturb and Observe (P&O) MPPT algorithm is utilized [9], where the annoyance step-size  $v_{step}$  and the MPPT sampling rate  $f_{MPPT}$  are the MPPT parameters. One significant quality of the P&O MPPT algorithm (and additionally other slope climbing MPPT techniques) is the power oscillation during the consistent state activity [9]. This conduct is appeared in Fig. 2, where the PV inverter operates under steady solar irradiance condition. Two MPPT sampling rates of 2.5 Hz and 5 Hz are utilized to demonstrate the presentation of the PV system with various MPPT sampling rates. Contrasting the working condition and multiple times distinction in the sampling rate can obviously demonstrate their effect on the interharmonic attributes. It tends to be seen that the PV clusters voltage sways inside three working points, which compare to the "highest point of the slope" in the power voltage normal for the PV exhibits. Quite, the frequency of the oscillation is relative to the MPPT sampling rate.

#### IV.MITIGATION

##### INTERHARMONICS:

A. Modifying MPPT Sampling Rate  
Conventionally, the P&O MPPT algorithm is implemented with a fixed sampling rate, where a high sampling rate offers a high MPPT efficiency during fast changing environmental conditions [12]. However, as it has been shown

OF

in Fig. 4(b), this can introduce certain interharmonics in the output current.

Using a random sampling rate for the MPPT algorithm is one way to reduce the dominant interharmonics in the output current. This concept is analogous to the random Pulse Width Modulation (PWM) discussed in previous research for PWM switching harmonic reduction [13]. However, in the proposed method, the sampling rate is chosen at random by the MPPT algorithm. One simple way to implement this method is to randomly select the MPPT algorithm sampling rate during the operation, either at a high or low  $f_{slow}$  value. which can be summarized as:

$$f_{MPPT} = \begin{cases} f_{fast}, & \text{when } X \leq 0.5 \\ f_{slow}, & \text{when otherwise} \end{cases}$$

where  $X \sim U(0, 1)$  is a random variable with uniform distribution between 0 and 1. Notably, there are also other ways to randomly generate different sampling rates during the operation, which is an interesting aspect for future research.

#### V.RESULTS

A. Output current and DC link voltage of the PV inverter at the MPPT sampling rate of  $f_{slow}=2.5\text{Hz}$

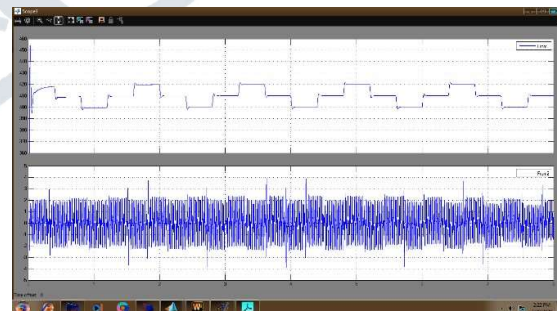
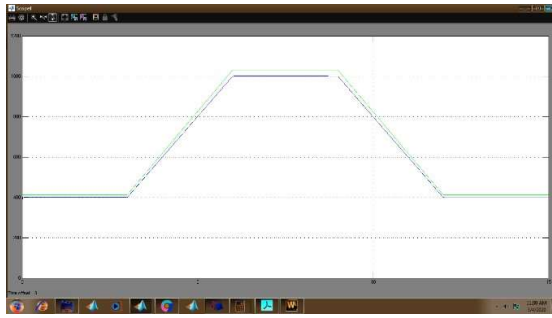
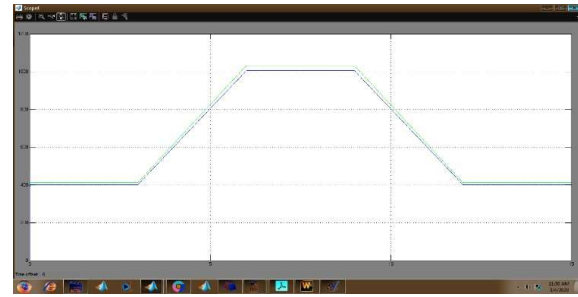

Fig 2:DC link voltage and Outputcurrent

Fig 3:Efficiency at  $f_{\text{slow}}=2.5\text{Hz}$ Fig 7 :Efficiency at  $f_{\text{slow}}=2.5\text{Hz}$ 

**B. Output current and DC link voltage of the PV inverter at the MPPT sampling rate of  $f_{\text{slow}}=5\text{ Hz}$**

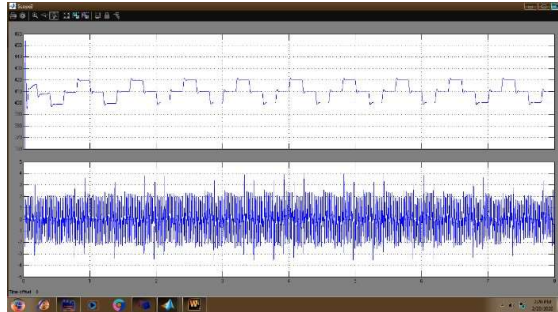
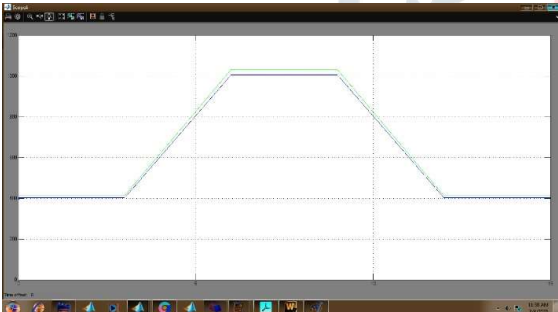

Fig 4: DC link voltage and output current

Fig 5: Efficiency at  $f_{\text{max}}=5\text{Hz}$ 

**C. Output current and DC link voltage of the PV inverter at the MPPT sampling rate of  $f_{\text{mppt}}=\text{random}$**

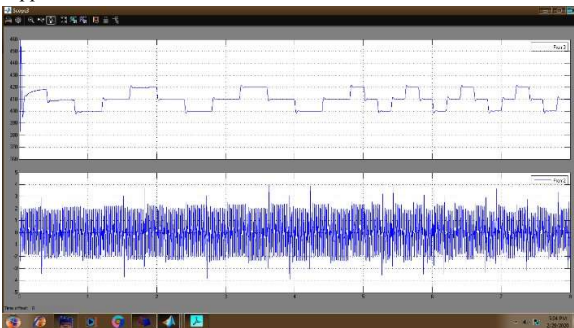

Fig 6 :DC link voltage and Outputcurrent

## VI.CONCLUSION

When choosing the sampling rate of the MPPT algorithm for conventional MPPT execution, there is a trade-off between interharmonic emission and MPPT efficiency. In order to address this issue, another moderating solution for interharmonics in PV systems is proposed in this paper. The proposed strategy adjusts the MPPT algorithm during operation by randomly selecting the sampling rate of the MPPT algorithm. Furthermore, the proposed mitigating solution's MPPT execution can be kept near the previous MPPT technique with a fast MPPT sampling rate, allowing for comparative tracking productivity during a unique working condition.

## REFERENCES

- [1] M. Aiello, A. Cataliotti, S. Favuzza, and G. Graditi, "Theoretical and experimental comparison of total harmonic distortion factors for the evaluation of harmonic and interharmonic pollution of grid-connected photovoltaic systems," *IEEE Trans. Power Del.*, vol. 21, no. 3, pp. 1390–1397, Jul. 2006.
- [2] T. Messo, J. Jokipii, A. Aapro, and T. Suntio, "Time and frequencydomain evidence on power quality issues caused by grid-connected three-phase photovoltaic inverters," in *Proc. EPE*, pp. 1–9, Aug. 2014.
- [3] R. Langella, A. Testa, S. Z. Djokic, J. Meyer, and M. Klatt, "On the interharmonic emission of PV inverters under different operating conditions," in *Proc. ICHQP*, pp. 733–738, Oct. 2016.
- [4] R. Langella, A. Testa, J. Meyer, F. Miller, R.

Stiegler, and S. Z. Djokic, "Experimental-based evaluation of PV inverter harmonic and interharmonic distortion due to different operating conditions," *IEEE Trans. Instrum. Meas.*, vol. 65, no. 10, pp. 2221–2233, Oct. 2016.

[5] P. Pakonen, A. Hilden, T. Suntio, and P. Verho, "Grid-connected PV power plant induced power quality problems - experimental evidence," in *Proc. EPE*, pp. 1–10, Sep. 2016. [6] V. Ravindran, S. K. Rnnberg, T. Busatto, and M. H. J. Bollen, "Inspection of interharmonic emissions from a grid-tied PV inverter in north Sweden," in *Proc. ICHQP*, pp. 1–6, May 2018.

[7] A. Testa, M. F. Akram, R. Burch, G. Carpinelli, G. Chang, V. Dinavahi, C. Hatziaodoniu, W. M. Grady, E. Gunther, M. Halpin, P. Lehn, Y. Liu, R. Langella, M. Lowenstein, A. Medina, T. Ortmeier, S. Ranade, P. Ribeiro, N. Watson, J. Wikston, and W. Xu, "Interharmonics: Theory and tracking algorithms," *IEEE Trans. Power Electron.*, vol. 33, no. 2, pp. 1284–1293, Feb. 2018. Electrical

[12] H. Schmidt, B. Burger, U. Bussemas, and "How fast does an mpp tracker really to be?" in *Proc. EU PVSEC*, pp. 3273–3276, Sep. 2009.

[13] F. Blaabjerg, J. K. Pedersen, and P. Thøgersen, "Improved modulation techniques for PWM-VSI drives," *IEEE Trans. Ind. Electron.*, vol. 44, no. 1, pp. 87–95, Feb. 1997.

#### Author's Profile:



Mr. T. Srikanth received B. Tech Degree in Electrical & Electronics Engineering from J.N.T.U.H, Hyderabad., and M. Tech Degree in Power Electronics Drives from SRM University Chennai. Currently working as Associate Professor at Sree Venkateswara College of Engineering, North Rajupalem, Nellore, A.P.

modeling," *IEEE Trans. Power Del.*, vol. 22, no. 4, pp. 2335–2348, Oct. 2007.

[8] A. Sangwongwanich, Y. Yang, D. Sera, H. Soltani, and F. Blaabjerg, "Analysis and modeling of interharmonics from grid-connected photovoltaic systems," *IEEE Trans. Power Electron.*, vol. 33, no. 10, pp. 8353–8364, Oct. 2018.

[9] N. Femia, G. Petrone, G. Spagnuolo, and M. Vitelli, "Optimization of perturb and observe maximum power point tracking method," *IEEE Trans. Power Electron.*, vol. 20, no. 4, pp. 963–973, Jul. 2005.

[10] S.B. Kjaer, J.K. Pedersen, and F. Blaabjerg, "A review of single-phase grid-connected inverters for photovoltaic modules," *IEEE Trans. Ind. Appl.*, vol. 41, no. 5, pp. 1292–1306, Sep. 2005.

[11] J. Kivimaki, S. Kolesnik, M. Sitbon, T. Suntio, and A. Kuperman, "Design guidelines for multiloop perturbative maximum power point



Vivek is currently pursuing B. Tech Degree in Electrical & Electronics Engineering from Sree S. Elies, Venkateswara College Of Engineering, North Rajupalem, Nellore, A.P.



Mr.P.Ramesh, received graduate degree in electrical and electronics engineering from JNTUA, Ananthapuram and post-graduation degree specialization of electrical power systems from JNTUA,

ANANTHAPURAM and presently working as assistant professor in EEE Department At Sree Venkateswara College of Engineering, North Rajupalem, S.P.S.R Nellore,A.P .



G.Sivakumar is currently pursuing B. Tech Degree in Electrical & Electronics Engineering from Sree Venkateswara College Of Engineering, North Rajupalem, Nellore,A.P.



P.Beaula is currently pursuing B. Tech Degree in Electrical & Electronics Engineering from Sree Venkateswara College Of Engineering, North Rajupalem, Nellore, A.P.

