

## Mitigation of Harmonics in A Distribution System Using Shunt Active Power Filter

<sup>1</sup>S. Narmadha, <sup>2</sup>K. Ratna Jyothy, <sup>3</sup>K. Krishna Priya, <sup>4</sup>Sd. Reena, <sup>5</sup>Ch. Rajkumar, <sup>6</sup>Sk.Fayaz

<sup>1</sup>Associate Professor, <sup>2</sup>Associate Professor, <sup>3,4,5&6</sup>B. Tech Student

Electrical and Electronics Engineering, Sree Venkateswara College of Engineering, Nellore, Andhra Pradesh, India.

---

### ARTICLE INFO

Article History:

Accepted: 05 April  
2023

Published: 20 April  
2023

Publication Issue  
Volume 10, Issue 2  
March-April-2023

Page Number Now-a-  
days, power system  
network is more  
complex and most the

---

### ABSTRACT

loads are inductive in nature. Switching of large inductive loads, causes a drop in the voltage at the load bus due to increase in VAR demand which lead to voltage instability. In order to keep the voltage within a limit. Reactive power compensation device such as TCSC, UPFC, SAPF etc., are employed. In utility applications, a SAPF provides leading or lagging reactive power to achieve system stability during transient conditions. The main objective is to control the dynamic behavior of interconnected power system. For enhancing the power quality SAPF is using with neural network controller. A neural network controller is used to generate gate pulse for each leg of voltage source converter of SAPF for both linear and nonlinear loads. The neural network controlled SAPF has been simulated for current balancing and harmonic compensation. The simulation is carried out in MATLAB and the result shows the performance of the proposed PSO-SRFPI controller is more effective than other conventional controllers.

---

Keywords : SAPF, VSI, hysteresis band current controller, Kp, Ki, THD.

### I. INTRODUCTION

For the past few decades, the rapid rise in non-linear loads usage has aggravated the major concern of power quality. Power quality refers to voltage and current waveforms being purely sinusoidal and in phase. Pure sinusoidal power is generated &

delivered by the generating stations. Non-linear loads consist of ac-dc converters,

switching devices, arc furnaces, adjustable speed drives (ASD) etc. Zero and negative sequence components derived from using single phase

injects voltage and current harmonics to the grid.

Further

unbalanced loads, voltage sag & swell, power-line flicker etc. generate harmonics [1]. In developing countries solar photovoltaics usage is also increasing rapidly as a microgrid system which too gives rise to harmonics in the established system of power grid.

Harmonics is explicated as a concoction of any kind of unwanted components which distorts the voltage and current waveforms. Unanticipated pulses are drawn from the grid by loads being non-linear. These unwanted pulses merge with source impedances and give rise to voltage and current distortion [2], [3]. Mark McGranaghan, in his research, stated that power electronics-based loads or non-linear loads are giving rise to the concern of harmonic distortion at the consumer's end more than ever [4]. Heat generating devices such as microwave ovens are generally sensitive to harmonics. Metering devices working inappropriately, the flow of unwanted neutral current, disturbance of drivers & motoring devices, resonance complications, electro-magnetic interference in communication systems, distribution power loss etc. are some of the major difficulties in the power system precipitated by harmonics [4], [5], [6].

Numerous researches have been accomplished and some are undergoing for reducing this harmonic distortion. Various devices are used to reduce harmonic contents such as in-line reactors or chokes, zigzag transformers, phase shifting transformers, isolation transformers, passive and active filters etc.,[7]

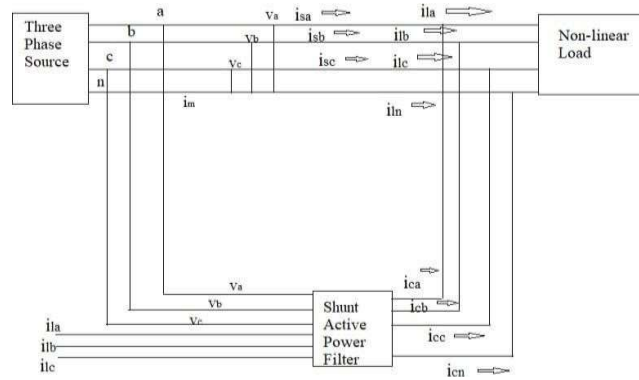

Fig.1: Basic structure of a SAPF

Amid those passive and active filters are the most prevailing devices used in recent years. Passive filters, having some drawbacks like new resonance creating, bulkiness, working on specific reactive power, have elevated the use of active power filters (APF). Different mechanisms are going under research regarding APF development [2], [8]. Series APF require major modification in the established grid lines. Hence, in this paper a shunt APF topology is used to reduce the harmonic contents. Fig. 1 shows the basic structure of a SAPF.

## II. SHUNT ACTIVE POWER FILTER

A voltage-sourced converter (VSC) with PWM provides a faster control that is required for flicker mitigation purpose. A PWM operated VSC utilizing IGBTs and connected in shunt is normally referred to as "STATCOM" or "SAPF" [9]. A shunt-connected synchronous machine has some similarities with the STATCOM, but does not contain power electronics. The capability of the synchronous machine to supply large reactive currents enables this system to lift the voltage by 60% for at least 6s. SAPF has the same structure as that of an STATCOM. It can potentially be used in the context of FACTS at the transmission level, custom power controllers at the distribution level and in end users' electrical installations.

Performance of SAPF in various modes, including power factor correction mode and AC voltage regulation mode has been analyzed through

simulations. This provides a validated benchmark model for simulation studies of the pulse widthmodulated SAPF. Phase-locked

loop (PLL) technique is used for voltage sag detection and mitigation. However, this technique provides good results only if voltage sag is not coupled with phaseangle jump.

SAPF is primarily a compensating device. SAPF generates current for compensation having an identical magnitude but at a phase opposite with the harmonic current. It uses switching strategy of devices of power electronics to generate the current for compensation. The SAPF scheme investigated here is constructed with a voltage source inverter (VSI). The VSI is controlled by current pulses triggered by PWM. The VSI is concluded to be the foremost unit of a SAPF system [10]. In this paper MOSFET is used in the VSI to attain the desired current waveform for cancelling the current harmonics. Perfect control of switching of the VSI is obligatory to obtain the required current waveshape. This pulses for actuating the gate of MOSFET is generated by a controller of the hysteresis band current (HBC). This switching tactics for VSI is the most preferred mechanism for current controlled VSI.

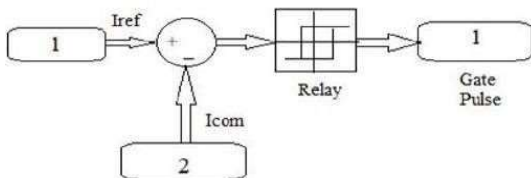

Fig.2: Hysteresis band current controller

In Fig. 2 a traditional single-phase HBC controller is shown where  $I_{com}$  is the actual compensating VSI output current and  $I_{ref}$  is the reference current. This reference current generation is the main concern as there are many renowned strategies established regarding this issue.

### III. PROPOSED METHOD PARTICAL SWARM OPTIMIZATION- PI CONTROLLER

Particle swarm optimization (PSO) is a population based stochastic optimization technique developed by Dr. Eberhart and Dr. Kennedy in 1995, inspired by social behavior of bird flocking or fish schooling [11]. PSO shares many similarities with evolutionary computation techniques such as Genetic Algorithms (GA). The system is initialized with a population of random solutions and searches for optima by updating generations. However, unlike GA, PSO has no evolution operators such as crossover and mutation. In PSO, the potential solutions, called particles, fly through the problem space by following the current optimum particles. In past several years, PSO has been successfully applied in many research and application areas. It is demonstrated that PSO gets better results in a faster, cheaper way compared with other methods. Compared to GA, the advantages of PSO are that PSO is easy to implement and there are few parameters to adjust. One version, with slight variations, works well in a wide variety of applications. Particle swarm optimization has been used for approaches that can be used across a wide range of applications, as well as for specific applications focused on a specific requirement. PSO has been successfully applied in areas like, function optimization, artificial neural network training, fuzzy system control, and other areas where GA can be applied [12].

#### A. THE PSO ALOGRITHM

As stated before, PSO simulates the behaviors of bird flocking. Suppose the following scenario: a group of birds are randomly searching food in an area. There is only one piece of food in the area being searched. All the birds do not know where the food is. But they know how far the food is in each

iteration. So, what is the best strategy to find the food. The effective one is to follow the bird which is nearest to the food. PSO learned from the scenario and used it to solve the optimization problems [13]. In PSO, each single solution is a "bird" in the search space which is called it as "particle". All of particles have fitness values which are evaluated by the fitness function to be optimized, and have velocities which direct the flying of the particles. The particles fly through the problem space by following the current optimum particle. PSO is initialized with a group of random particles (solutions) and then searches for optima by updating generations. In every iteration, each particle is updated by following two "best" values. The first one is the best solution (fitness) it has achieved so far. (The fitness value is also stored.)

This value is called pbest. Another "best" value that is tracked by the particle swarm optimizer is the best value, obtained so far by any particle in the population. This best value is a global best and called gbest. When a particle takes part of the population as its topological neighbors, the best value is a local best and is called lbest.

## B. PSO PARAMETER CONTROL

There are two key steps when applying PSO to optimization problems:

1. The representation of the solution and
2. The fitness functions.

One of the advantages of PSO is that PSO take real numbers as particles. It is not like GA, which needs to change to binary encoding, or special genetic operators must be used. For example, we try to find the solution for  $f(x) = x_1^2 + x_2^2 + x_3^2$ , the particle can be set as  $(x_1, x_2, x_3)$ , and fitness function is  $f(x)$ . Then we can use the standard procedure to find the optimum. The searching is a repetitive process, and the stopping criteria are that the maximum iteration number is reached or the minimum error condition

is satisfied. There are not many parameters need to be tuned in PSO [14]. Here is a list of the parameters and their typical values:

1. The Number of Particles
2. Dimension of Particles
3. Learning Factors

## C. TUNING OF PI CONTROLLER BY USING PSO

The PI controller was the most popular controller of this century because of its remarkable effectiveness, simplicity of implementation and broad applicability. The combination of proportional and integral terms is important to increase the speed of the response and also to eliminate the steady state error. In practice, it is hard to obtain optimal tuning for PI controller. Most of PI tuning is done manually which is difficult and time consuming. In order to use PI controller better, the optimal tuning of its parameters have become an important. Here the PI controller is tuned by the PSO Algorithm [15].

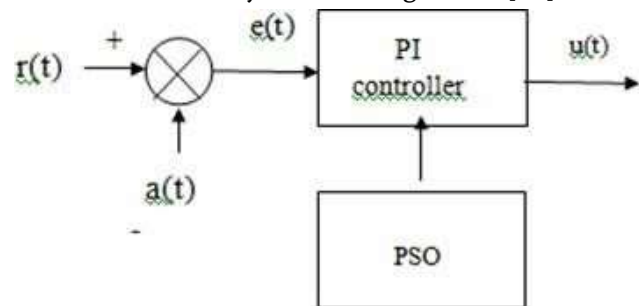

Fig.3: Block diagram of PSO based PI controller

The PI controller has the Proportional ( $K_p$ ) and Integral gains ( $K_i$ ). The block diagram of the proposed PI controller is shown below, where  $r$ ,  $e$ ,  $u$ ,  $a$  are respectively the reference, error, controller output and actual variables.

## IV. SIMULATION & RESULTS

The researched system is modelled and simulated in MATLAB/ SIMULINK, need for simulation and simulation results of the Distribution SAPF System for improving the Power Quality at the distribution system. Performance of the proposed SHAPF with neural network controller system is shown under different system conditions for linear and nonlinear loads.

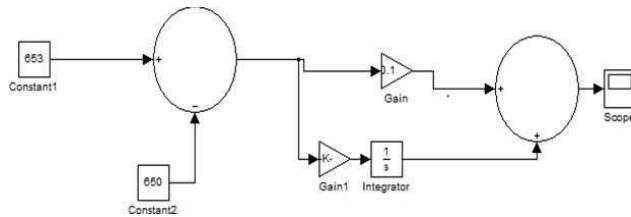

Fig.4: Simulation block of PSO based PI controller

Here the figure 4 is saved as pi.mdl. This pi.mdl file is taken into the objective function program by using the command `sim('pi', [0,1.2])` such that 0 - 1.2 is the time period. This entire objective function is taken into the main program and is run to obtain the output.

SIMULINK is software for modeling, simulating, and analyzing Dynamic systems. It supports linear and nonlinear systems, modeled in continuous time, sampled time, or a hybrid of the two. Systems can also be multi rate i.e., have different parts that are sampled or updated at different rates. SIMULINK

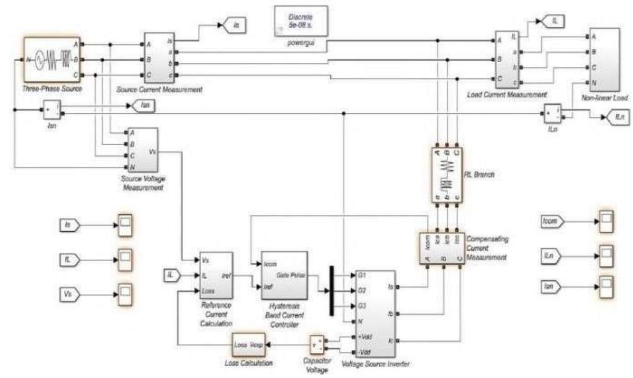
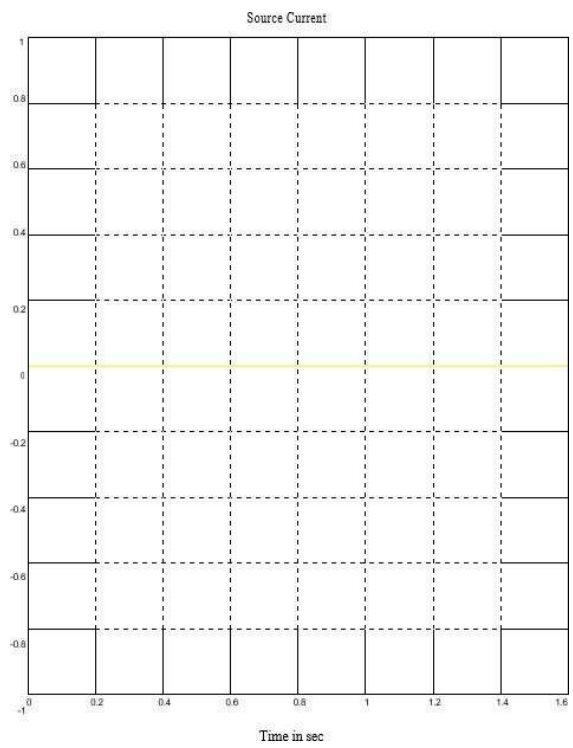
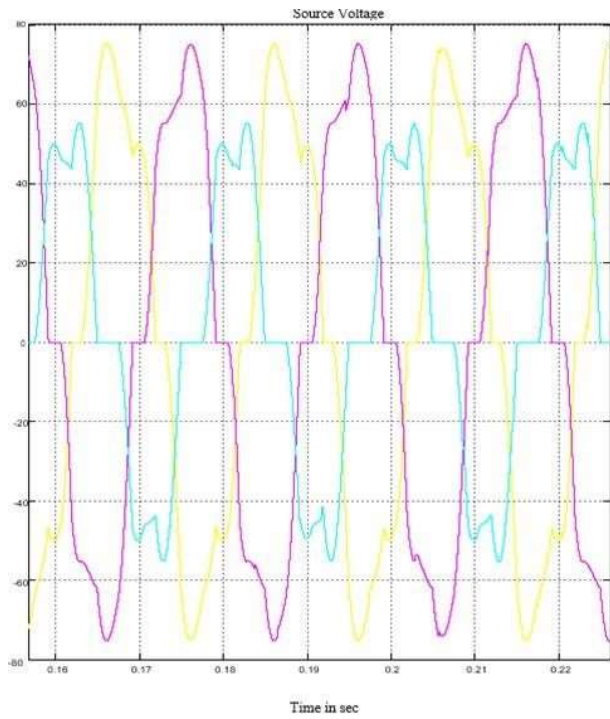

Fig.5: Simulink model of PSQPI theory

enables you to pose a question about a system, model it and see what happens. With SIMULINK one can easily build models from scratch or take an existing model and add to it. Thousands of engineers around the world use SIMULINK to model and solve real problems in a variety of industries. When a new control strategy of a converter or a drive system is formulated, it is often convenient to study the system performance by simulation before building the breadboard or prototype. The simulation not only validates the systems operation but also permits optimization of the systems performance by iteration of its parameters. Besides control and circuit parameters the plant parameter variation effect can be studied. Valuable time is thus saved in the development and design of the product and the failure of components of poorly designed systems can be avoided. The simulation program also helps to generate real time controller software codes for downloading to a microprocessor or digital signal processor.

### V. Simulation Results for Proposed Method

a). Compensation current provided by SAPF (PSO-PI)



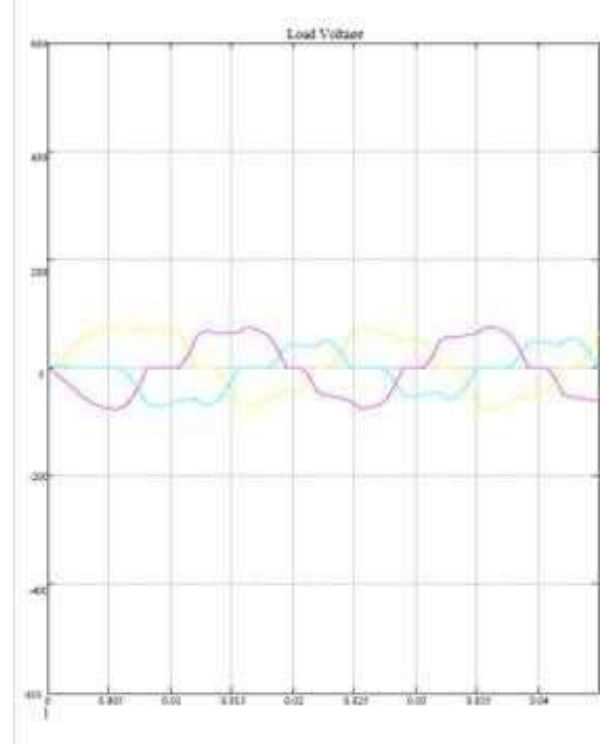
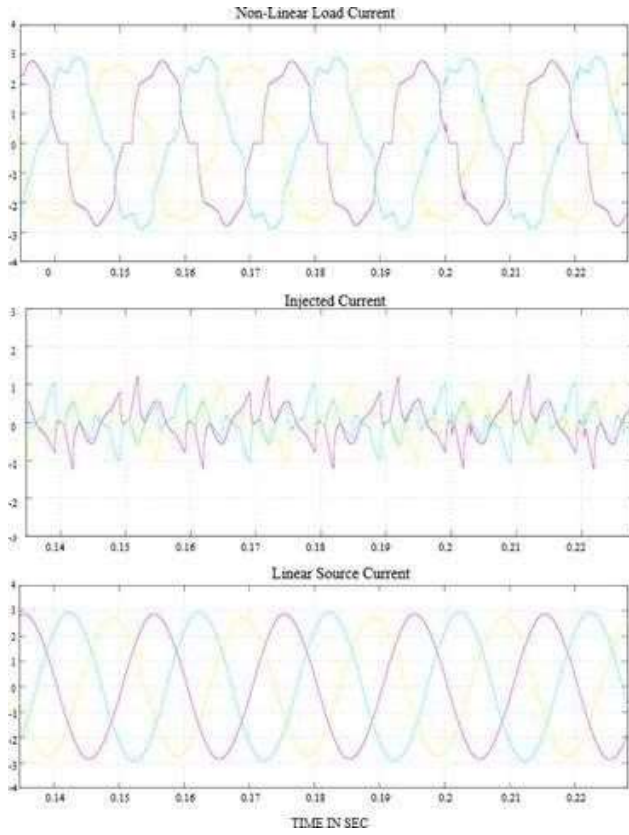

d) Three Phase Load Voltage Using SAPF

b). Three Phase of Source Voltage Using SAPF

c)

Three Phase Neutral Source Current Using SAPF

e) Three Phase Load Current Using SAPF

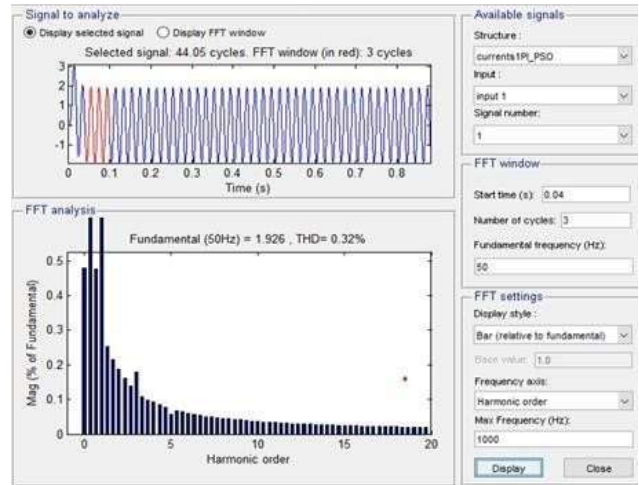
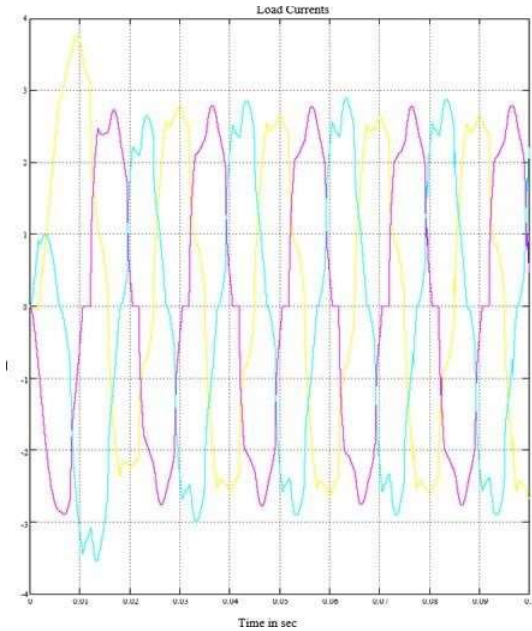

f) %THD in Current with PSO-PI controller

Total Harmonic Distortion (THD):

Current harmonics is usually generated by harmonics contained in voltage supply and depends on the type of load such as resistive load, capacitive load, and inductive load. Harmonic generated by load are caused by nonlinear operation of devices, including power converters arc-furnaces, gas discharge lighting devices, etc. Load harmonics can cause the overheating of the magnetic cores of transformer and motors.

The SIMULINK Model of proposed SAPF, and it is simulated in MATLAB SIMULINK to test the performance of the control method. The PI controller is used to generate gate pulses of each of VSC of SAPF. The main difference is in the control strategy for generating reference current. These strategies were discussed previously. Inside the reference current calculation simulation diagram the control strategies are given based on SRF theory. Each phase of the nonlinear load contains RL load supplied after rectification by a diode. The values of each RL load for each phase are given in Table-1

Phase	Non-Linear Load (unbalanced)	
	Value of Resistance	Value of Inductance
A	80 Ohms	1.75H
B	65 Ohms	1.35H
C	70 Ohms	1.55H



Table – 1: Values of each RL load for each phase

THD was measured by FFT analysis. The THD for nonlinear load current is found to be 47.95% which is needed to be compensated at the source end. After using SRF theory based SAPF the THD is reduced and found to be 1.37% at the source end. This value is within the standard given in IEEE 519. After using PSO-PI theory based SAPF the same THD is reduced to 0.32% which is less than SRF theory based SAPF. The THD values are summarized in Table- II.

Table-II: THD Values of Load Currents

Parameter	SAPF with dq0-PI control	SAPF with PSO-PI control
%THD of Current	1.37%	0.32%

## VI.CONCLUSION

The microgrid system is a new horizon in developing countries. This accompanying with non-linear loads hampers the total quality of electrical energy. Hence, this paper investigates power quality refining techniques. SAPF is the best of different compensation techniques. The inspected strategies in this paper for SAPF controlling illustrates harmonic reduction to be within standard designated by IEEE-519. Amid the studied strategies PSO-PI theory controlled SAPF demonstrated superior results by retrieving source current faster, diminishing THD to 0.32% and keeping neutral current of source less fluctuating. During unbalanced grid voltage conditions. Further research and development could build on this work, with the goal of making ANFIS controllers an integral part of wind turbine systems for enhanced efficiency and stability.

## VII.REFERENCES

- [1]. M. A. Kabir and U. Mahbub, "Synchronous detection and digital control of Shunt Active Power Filter in power quality improvement," 2011 IEEE Power and Energy Conference at Illinois, Champaign, IL, 2011, pp. 1-5.
- [2]. A. F. H. Nohra, M. Fadel and H. Y. Kanaan, "A novel instantaneous power-based control method for a four-wire SAPF operating with highly perturbed mains voltages," 2016 IEEE International Conference on Industrial Technology (ICIT), Taipei, 2016, pp. 1236-1241.
- [3]. C. K. Najiya, T. Krishnakumari, G. Sijo, "Shunt Active Power Filter based on SRF theory and Hysteresis Band Current Controller under different Load conditions," IOSR Journal of Electrical and Electronics Engineering (IOSR-JEEE), pp. 20-26, 2017.
- [4]. M. McGranaghan, "Active Filter design and specification for control of Harmonics in Industrial and Commercial Facilities," 2001.
- [5]. A. Emadi, A. Nasiri, and S. B. Bekiarov, "Uninterruptible Power Supplies and Active Filter," Florida, 2005, pp. 65-111.
- [6]. M. Y. Lada, I. Bugis, M. H. N. Talib, "Simulation a Shunt Active Power Filter using MATLAB/Simulink," 2010 4th International Power Engineering and Optimization Conf. (PEOCO), Shah Alam, Malaysia, 2010, pp. 371375.
- [7]. R. C. Dugan, M. F. McGranaghan, and H. W. Beaty, "Electrical power system quality," McGraw-Hill, New York, 1996.
- [8]. Y. Hoon, M. A. M. Radzi, M. K. Hassan and N. F. Mailah, "Three-phase three-level shunt active power filter with simplified

synchronous reference frame,” 2016 IEEE Industrial Electronics and Applications Conf. (IEACon), Kota Kinabalu, 2016, pp. 1-6.

- [9]. Y. Hoon, M. A. M. Radzi, M. K. Hassan and N. F. Mailah, “Threephase three-level shunt active power filter with simplified synchronous reference frame,” 2016 IEEE Industrial Electronics and Applications Conf. (IEACon), Kota Kinabalu, 2016, pp. 1-6.
- [10]. Lee GM, Lee DC, Seok JK. Control of series active power filters compensating for source voltage unbalance and current harmonics. IEEE Transactions on industrial electronics. 2004; 51(1): 132-139.
- [11]. Kennedy, J.; Eberhart, R. (1995). "Particle Swarm Optimization". Proceedings of IEEE International Conference on Neural Networks. Vol. IV. pp. 1942–1948.
- [12]. Zhang, Y. (2015). "A Comprehensive Survey on Particle Swarm Optimization Algorithm and Its Applications". Mathematical Problems in Engineering. 2015: 931256.
- [13]. JamesBlondin, “Particle Swarm Optimization: A Tutorial”, September 4, 2009.
- [14]. Yuhui Shi, Russell Eberhart, “A Modified Particle Swarm Optimizers”, IEEE, 1998.
- [15]. W. Cao, M. Wu, J. Zhao, W. Liu and Y. Lu, "An improved current-limiting strategy for shunt active power filter (SAPF) using particle swarm optimization (PSO)," in IEEE Applied Power Electronics Conference and Exposition (APEC), San Antonio, TX, USA, 2018, pp. 494498.

#### AUTHORS PROFILE



Mrs. S. Narmadha, received graduate degree in Electrical and Electronics Engineering from

University of Madras and Post- graduation with specialization in Power Electronics and Industrial Drives from Sathyabama University. Presently working as an Associate Professor in EEE Department at Sree Venkateswara College of Engineering, North Rajupalem, S.P.S.R Nellore, A.P. E mail Id: [snarmadhasasi@gmail.com](mailto:snarmadhasasi@gmail.com)



Mrs K. Ratna Jyothy received graduate degree in Electrical and Electronics Engineering from SKD University, Anantapuramu and Post graduation degree

specialization of Electrical Power Engineering from JNTUH, Hyderabad and Pursuing Ph.D in JNTUK, Kakinada and Presently working as an Associate Professor in EEE department in Sree Venkateswara College of Engineering, Northrajupalem, Kodavaluru, SPSR Nellore, A.P.EEE, Sree Venkateswara College of Engineering, North Rajupalem, S.P.S.R. Nellore, A.P. E mail Id: [krjm921@gmail.com](mailto:krjm921@gmail.com)



KASIREDDY KRISHNA PRIYA currently pursuing B. Tech in Electrical and Electronics Engineering from Sree Venkateswara College of Engineering, North Rajupalem,

S.P.S.R. Nellore.  
E mail Id: krishnapriyakasireddy321@gmail.com



SYED REENA currently pursuing  
B. Tech in Electrical  
and  
Electronics Engineering from Sree  
Venkateswara College of  
Engineering, North Rajupalem, S.P.S.R.

Nellore.

E mail Id: syedreena25@gmail.com



CHERUBU RAJKUMAR currently  
pursuing B. Tech in Electrical and  
Electronics  
Engineering from Sree  
Venkateswara College of

Engineering, North

Rajupalem, S.P.S.R. Nellore.

E mail Id: rajkumar.cherubu@gmail.com



SHAIK FAYAZ currently pursuing  
B. Tech in  
Electrical and Electronics  
Engineering from Sree  
Venkateswara College of  
Engineering, North Rajupalem,

S.P.S.R. Nellore.

E mail Id: shaikfayaz9@gmail.com

Cite this article as :

S. Narmadha, K. Ratna Jyothy, K. Krishna Priya, Sd.  
Reena, Ch. Rajkumar, Sk.Fayaz, "Mitigation of  
Harmonics in A Distribution System Using Shunt

Active Power Filter", International Journal of  
Scientific Research in Science, Engineering and  
Technology (IJSRSET), Online ISSN : 2394-4099,  
Print ISSN : 2395-1990, Volume 10 Issue 2, pp.  
527535, March-April 2023.

Journal URL : <https://ijsrset.com/IJSRSET2310276>